

13BOP-9

3,000 lbs. Capacity · Electric Order Picker

2,200 lbs. Capacity · Electric Order Picker with Auxiliary Lift

HYUNDAI

MATERIAL HANDLING

NO ONE DELIVERS MORE

MORE PRODUCTIVITY.
MORE POWER.
TO FILL MORE ORDERS
MORE PROFITABLY.



Get more of what you're looking for: THE 13BOP-9 FROM HYUNDAI

To pick more orders quickly you need a machine that features outstanding power, maneuverability, and operator comfort. You'll find all of this in the 13BOP-9. Engineered to deliver greater reliability shift after shift, the 13BOP-9 features an array of innovative features and advanced technology matched to a rugged, durable frame. Add in precise handling, outstanding visibility, simplified maintenance, available Li-ion power, and invaluable safety features, and you have a machine that will lift the performance of your entire operation.

If you want to fill orders more efficiently as you move pallets more economically, the 13BOP-9 is the order picker you should pick.



POWER AND PERFORMANCE YOU CAN RELY ON.

The 13BOP-9 is engineered to deliver greater productivity to your operation. It's proven, advanced components also assure greater reliability for less downtime and more uptime, picking orders and delivering greater profitability.

DRIVE MOTOR, PUMP MOTOR, AND BRAKE SYSTEM

The 13BOP-9 features an efficient, reliable AC motor that delivers superior performance and power at low noise levels. A temperature sensor ensures long motor life. It includes an electromagnetic brake for parking, which automatically deactivates when traveling. This negative-type braking system works by spring return force.

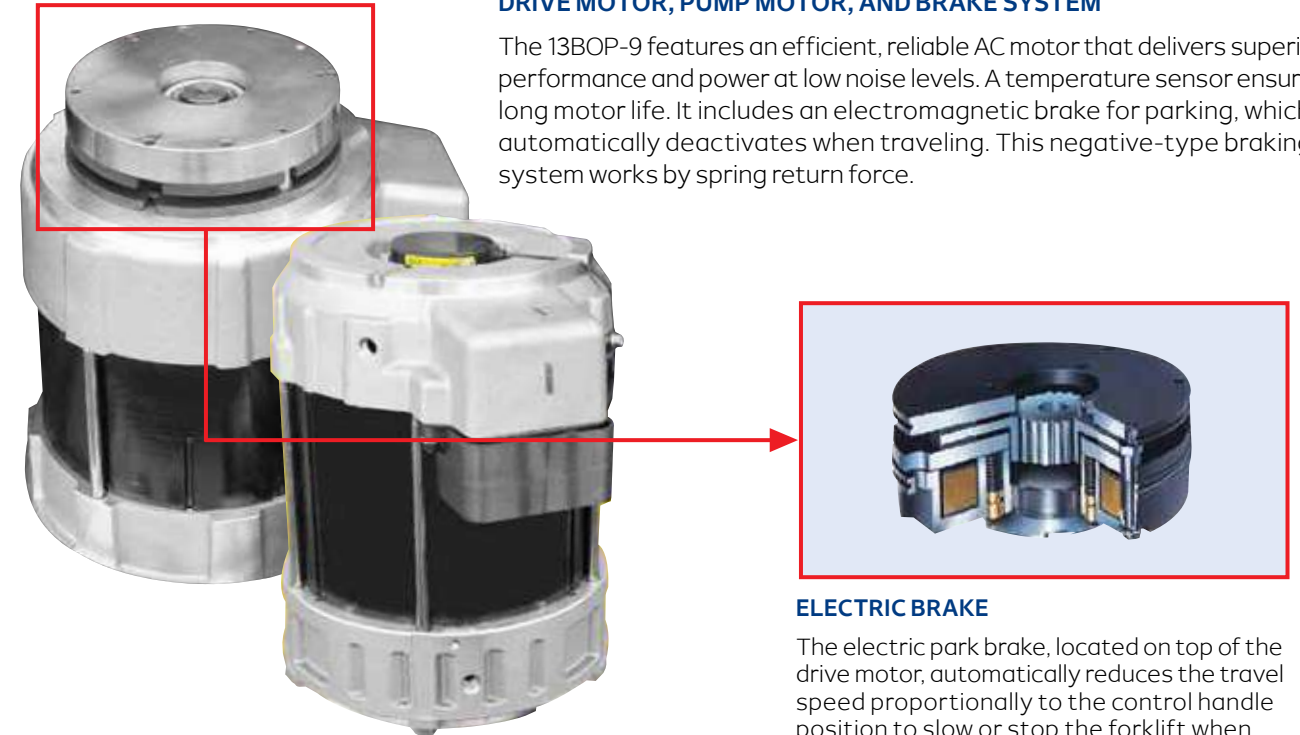

ELECTRIC BRAKE

The electric park brake, located on top of the drive motor, automatically reduces the travel speed proportionally to the control handle position to slow or stop the forklift when plugging or when the truck is turned off.

The 13BOP-9 Series offers you more:

Ergonomic Design

- Multifunction control handle (Lift/Lower, Travel, and Horn functions)
- Adjustable operator control panel (3" up or down)
- Safety bar on top of the dashboard (When operating wire guidance, the driver can maintain a comfortable posture)
- Added springs improve capacity and enhance platform stability
- Toe Board provides added safety

Optimal Performance

- Electric Power Steering (EPS) & Auto Steer Centering
- Optional wire guidance
- Optional fork height indicator with 50 presets
- Dual micom-type ZAPI controller
- Fast, easy access to service components
- Cushioned mast to reduce impact when platform moves up or down

Advanced Safety

- Travel speed managed with relation to platform height
- Password setting limits vehicle operation
- Slack Chain Indicator for loose lift chain detection
- Stable platform for more secure operation
- Strong overhead guard
- Padded, non-slip floormat, with dead man's switch to prevent accidents



DUAL MICOM CONTROLLER

The ZAPI AC controller with dual micom monitors the dual signals and detects faults for precise control and quick and secure servicing.



MAST COVER: PLATFORM CONTROL SYSTEM PROTECTION

A cover enhances the durability of the outer mast and protects the sensor and harnesses exposed on the side. This system reduces mast vibration for greater operator confidence when operating at higher lift heights. (TM-MAST only)

ADVANCED FEATURES TO WORK SMARTER NOT HARDER

The 13BOP-9 features innovative technology that helps you better manage your equipment, enhance machine performance, and improve operator productivity. It's all about delivering greater efficiency with greater economy.

ADVANCED MULTIFUNCTION DIGITAL CLUSTER

This advanced digital system clearly displays essential operational information in real time. It also includes buttons for easy setting of travel and mast operating speeds to match work conditions. You'll find innovative features everywhere:



- Onboard diagnostics, data logging, safety features, and maintenance tracking keep operators and service technicians informed
- Speed, accelerator level, steer angle, travel direction and operating hours are shown
- Other status information includes a battery discharge indicator, hour meter, working mode, and more
- Load weight indicator with an overload warning system helps safeguard the unit
- All the information is clearly visible in the 3.5" LCD color display



EPS & AUTO-CENTERING

The smooth operating electric power steering system (EPS) reduces operator fatigue and makes maneuvering easy, all while enhancing energy efficiency. The system automatically centers the steering when the key is turned on.



MULTIFUNCTION CONTROL HANDLE

With this unique system, operators can control the direction of travel, lifting and lowering the platform, and the horn, with just one hand, making order picking faster and easier.



EASY COMPONENT ACCESS

The 13BOP-9 is built to minimize downtime and simplify maintenance. With its unique design, the two-piece steel doors open to 180-degrees to allow easy access to all major components.

GREATER OPERATOR COMFORT FOR GREATER PRODUCTIVITY

Order picking can be a physically challenging job, but the 13BOP-9 offers important standard features that help to minimize operator fatigue shift after shift, while increasing the efficiency and productivity of your entire operation.

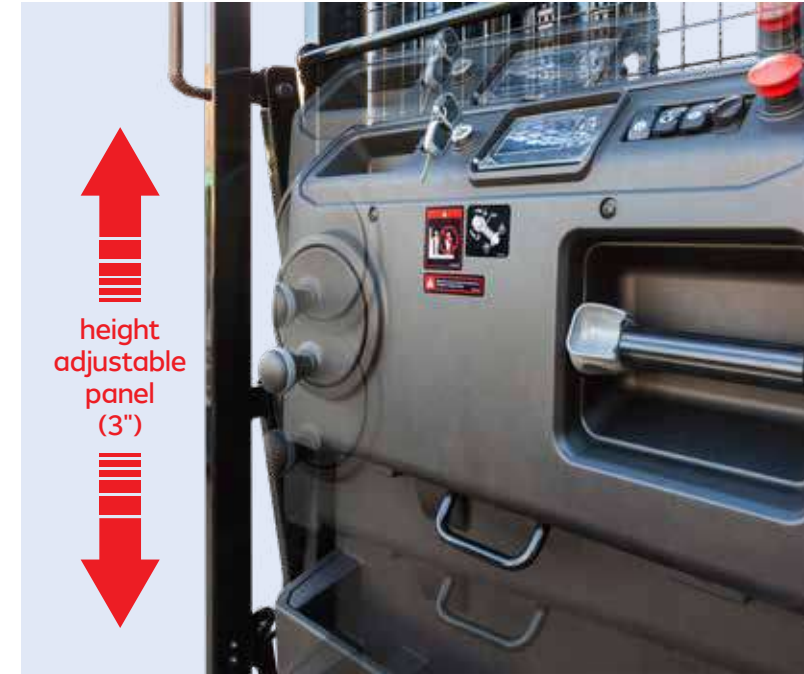

FULLY ADJUSTABLE CONTROL PANEL

The entire operator compartment of the 13BOP-9 is designed for maximum comfort. From its padded floormat to the overhead guard, operators will find a machine that gives them more control and visibility while reducing fatigue. At the heart of this system is the adjustable control panel.

- The control panel adjusts a full 3" in height for maximum operator efficiency with less effort
- This system also improves visibility allowing operators to pick orders more quickly and navigate around the warehouse with confidence

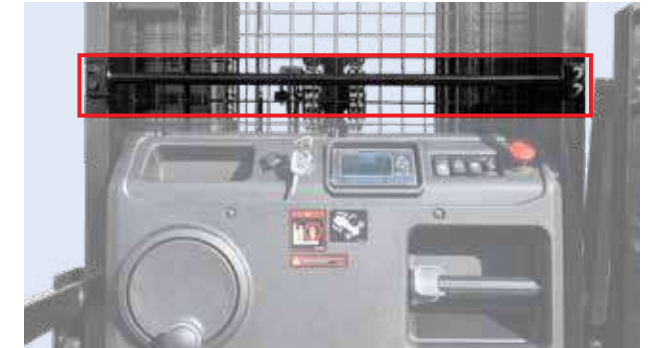

OPERATING PANEL TOP HANDLE

For added stability and enhanced safety, there is a handle on top of the operating panel. This simple but essential feature allows operators to maintain balance while driving and can also be used to securely hold a barcode reader.



STABLE PLATFORM

The 13BOP-9 features a spring on the chain anchor that reduces vibration when the platform moves between the primary and secondary cylinder. This feature reduces operator fatigue while creating more secure operation.

THE 13BOP-9 COMES WITH OUR BEST-IN-CLASS WARRANTY

Here's another way the 13BOP-9 will make you feel comfortable: it comes with Hyundai's 3-year, 4,000-hour warranty that sets a new standard for overall lowest cost of ownership.



STRONG OVERHEAD GUARD

The overhead guard offers exceptional visibility while providing protection from falling objects. The guard also includes work lights and cooling fans to maximize operator comfort.

WITH HYUNDAI, GREATER SAFETY IS ALWAYS A STANDARD FEATURE

At Hyundai, safety is never an option. That's why the 13BOP-9 features a comprehensive array of advanced safety features. Our goal is to maximize protection for the operator, those working around the forklift, your inventory, and your facilities.

CONTROLLED OPERATING SPEEDS

For the safety of operators working at elevated heights, the travel and lift speeds of the 13BOP-9 are gradually reduced based on the platform height and steer angle. The truck cannot travel when the platform reaches a height of 18 feet or more. In addition, the driving speed decreases significantly when the angle of the steering wheel exceeds 45 degrees.

Steering angle	Travel speed by platform height (mph)				
	~23.6 in	~59 in	~118 in	~217 in	~362 in
Angle < 10°	7.5	5.5	3.5	2.7	0
10° < Angle < 45°	7.5~3.7	5.5~1.2	3.5~0.4	2.7~0	0
Angle > 45°	7.5	1.2	0.4	0	0

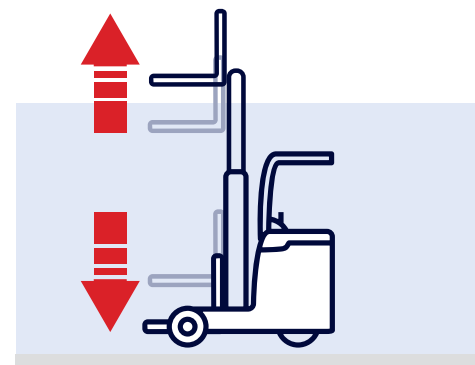
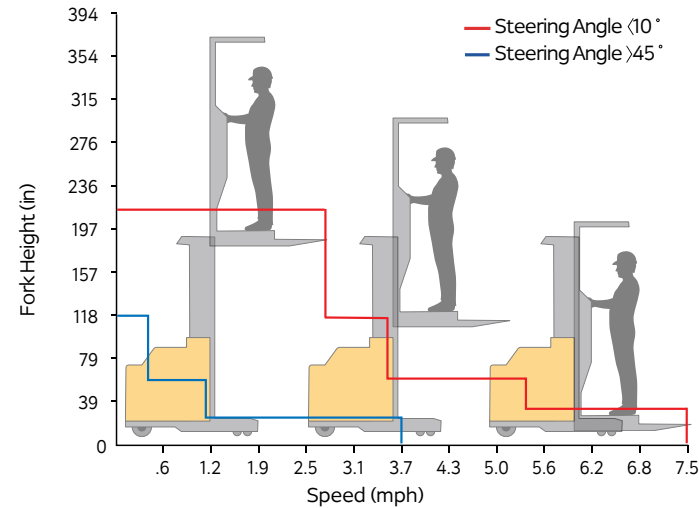

CUSHIONED MAST STOPS

To reduce the impact from the lift cylinder end stroke when the platform moves up or down, the platform's speed decreases before reaching the intended fork height and when nearing the ground.



PALLET CLAMP

The pantograph-type pallet clamp enhances clamping and can help prevent accidents if the pallet is shifted on the fork while operating.



PASSWORD SETTINGS

Passwords can be set on the cluster to prevent accidents caused when the vehicle is operated by unauthorized staff.

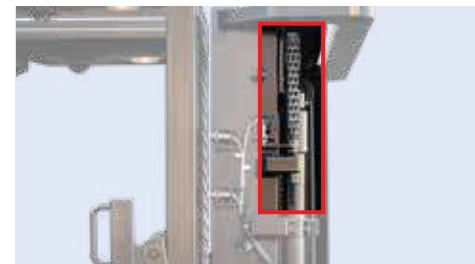

SLACK CHAIN DETECTION

If the fork is caught on the load beam, and the chain develops slack of approximately 1/10th of an inch, the mast stops lowering.



TOE BOARD

To assure that the operator's feet are always kept inside the vehicle during operation, a toe board has been added to the bottom of the safety bar.

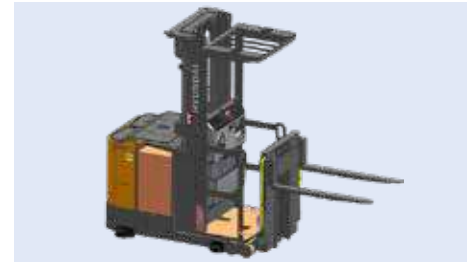

AUXILIARY LIFT

With this option, a mast on the front of the truck raises the fork 30°, allowing operators to pick orders without the stress and fatigue of bending over.

OPTIONS THAT LET YOU DO MORE, EARN, AND SAVE MORE

The 13BOP-9 features an unmatched array of standard features that can increase your productivity and profitability. Hyundai also offers options to meet your unique needs and maximize the potential in our equipment and your operation.



LITHIUM-ION BATTERY

The 13BOP-9 can deliver even greater uptime with a Li-ion battery. Hyundai Li-ion batteries feature rapid charging in just 2 hours and deliver outstanding performance. They're ideal for daily two-shift work by eliminating the need to replace batteries. Compared to lead-acid batteries, Li-ion batteries deliver 10% greater efficiency—for reduced energy and infrastructure costs with greater productivity and less downtime. They can substantially lower your costs thanks to:

- Significantly longer lifespan than lead-acid batteries
- No emission so no need for ventilated charging areas
- Virtually maintenance-free
- Less charging time
- Faster lifting and travel speeds
- Enhanced safety—Hyundai Li-ion batteries are UL approved and have a built-in fire suppression system



WIRE GUIDANCE

With this optional system the driving direction is automatically set responding to electric signals from wires in the floor. The result is safer, more comfortable operation without having to use the steering wheel—the operator is only required to drive forward or backward and operate the platform up or down.



GUIDE ROLLER

With this option, when the 13BOP-9 enters an aisle, the drive tire is automatically centered, allowing the operator to focus on picking for greater efficiency and safety.



HEIGHT INDICATOR

The optional height indicator has 50 presets to control the height of the platform up and down. When the driver selects a certain height and actuates the lift/lower function, the platform automatically stops at a designated height.

Dimensions

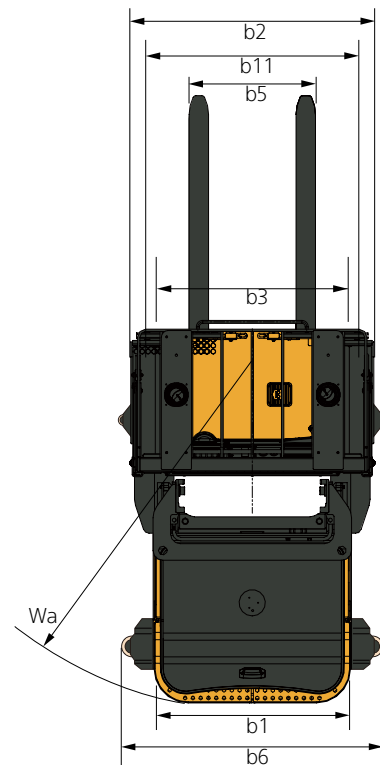
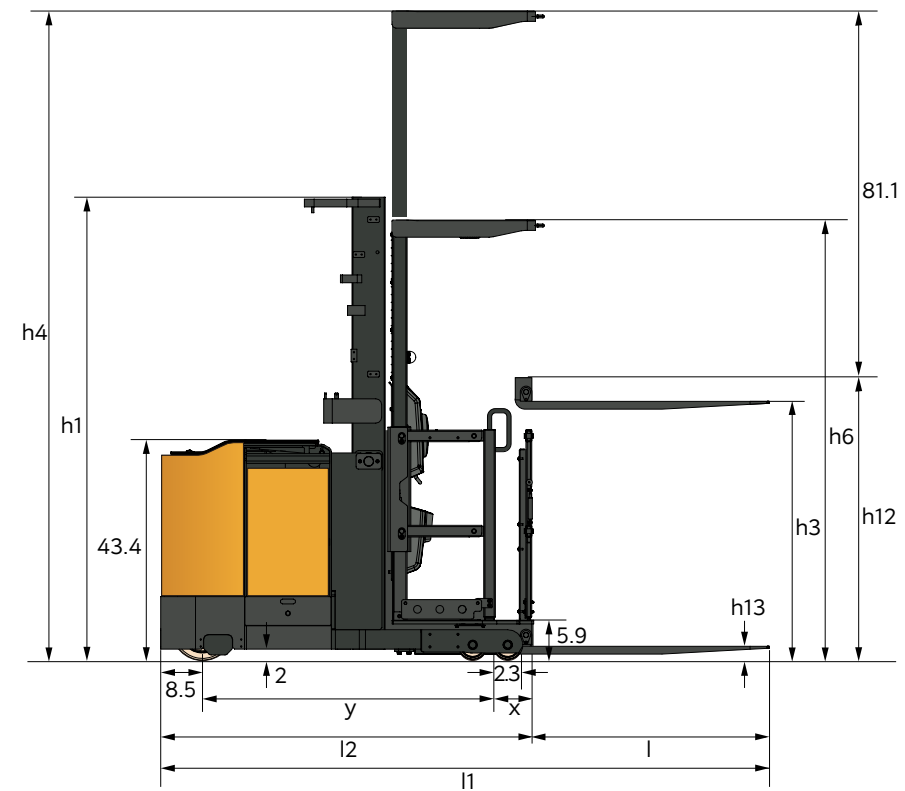

Specifications

Identification				
1.1	Manufacturer			Hyundai
1.2	Manufacturer's Type Designation			13BOP-9
1.3	Drive: Electric (Battery or Mains), Diesel, Petrol, Fuel Gas, Manual			Electric
1.4	Type Of Operation : Hand, Pedestrian, Standing, Seated, Order-Picker			Order Picker
1.5	Load Capacity / Rated Load	Q	lb	3,000
1.6	Load center distance	c	in	24
1.8	Load distance, center of front axle to fork	x	in	9.3
1.9	Wheelbase	y	in	58.3
Weights				
2.1	Service Weight		lb	6,469.5
2.2	Axle Loading, Loaded Front / Rear		lb	1,633.6 / 7,700.7
2.3	Axle Loading, Unloaded Front / Rear		lb	3,448 / 3,020.3
Wheels, Chassis				
3.1	Tires: Solid Rubber(V), Superelastic(SE), Pneumatic(P), Polyurethane(PE)			P
3.2	Tires Size, Front			12 x 5.5
3.3	Tires Size, Rear			6 x 3.9
3.5	Wheels, Number Front Rear (x=Driven Wheels)			1 x /4
3.6	Tread, Rear	b11	in	35.8
3.7	Tread, Rear, Wide frame	b11	in	43.7
Basic Dimensions				
4.2	Height, Mast lowered	h1	deg	87.4
4.4	Lift height	h3	In	128.9
4.5	Height, Mast extended	h4	In	215.4
4.7	Height of overhead guard	h6	In	89
4.8	Platform height (h13 + 5.315 in)	h7	In	7.9
4.11	Additional Lift	h9	In	-
4.14	Height, Platform raised (h3 + 5.315 in)	h12	In	134.3
4.14-1	Picking height (h12 + 62.99)	h28	In	197.2
4.15	Height lowered (Fork height)	h13		2.6
4.19	Overall Length	l1	in	117.3
4.20	Length to Face of Forks	l2	In	76
4.21	Overall Width	b1 / b2	in	40.2 / 49.2
	Overall Width, Wide frame			49.2
4.22	Fork Dimensions	L x W x H	in	1.6 x 3.9 x 41.3
4.25	Overall fork width	b5	in	25.6
4.26	Platform width	b3	in	40.2
	Platform width, Wide frame			49.2
4.27	Guide roller width	b6	in	see chart
4.32	Ground clearance, Center of wheelbase	m2	in	2
4.33	Working aisle width, with 31.5 x 47.24 crosswise	Ast	in	16.5
4.34	Working aisle width, with 31.5 x 47.24 lengthwise	Ast	in	138.1
4.35	Turning radius	Wa	in	71.6
Performance Data				
5.1	Travel Speed, Loaded / Unloaded		mph	7.5 / 7.5
5.2	Lift Speed, Loaded / Unloaded		ft / min	47.2 / 72.8
5.3	Lowering Speed, Loaded / Unloaded		ft / min	84.6 / 78.7
5.6	Acceleration time (over .39 in)		s	6.4
5.10	Service Brake			Electric Release
Electric Motor				
6.1	Drive Motor, Rating S2 60 min.		hp	5.8
6.2	Hoist Motor, Rating S3 15%		hp	12.2
6.4	Battery Voltage, Nominal Capacity K5		V / Ah	24 / 824 36 / 750
6.5	Battery Weight, Dependent on Manufacturer		lb	1,609.4
	Battery Compartment Dimensions	L x W x H	in	38.3 x 16.5 x 32.5
	Maximum Battery Dimensions	L x W x H	in	38.26 x 16.33 x 31.10
	Connector Location		in	A - 7.9
Additional Data				
8.1	Type of Drive Control			AC

*All specifications in this catalog are subject to change according to the optional items.

13BOP-9

Mast Type		Maximum Fork Height	Overall Height (lowered)	Overall Height with OHG (extended)	Free Lift Height with OHG	Load Capacity (w/o side shift)	Truck Weight (unloaded)
						24 in. LC	
		in	in	in	in	lbs	lbs
2-Stage Limited Free Lift	V355	141.1	93.5	227.2	0.0	3,000	6,526
3-Stage Full Free Lift	TF500	198.5	87.4	286.1	1.0	3,000	6,989
	TF530	211.2	93.5	297.2	7.1	3,000	7,082
	TF610	241.1	105.5	327.2	19.1	2,668	7,264
	TF685	271.2	117.5	357.2	31.1	2,447	7,472
	TF760	301.2	129.3	387.2	42.9	2,205	7,773
	TF930	367.4	158.5	453.4	72.0	1,742	8,337

* TF-Mast: A mast with 1 free lift cylinder in the center.
 * When TF Mast is applied, the overall width increases.

13BOP-9 (auxiliary lift (24V option only))

Mast Type		Maximum Fork Height (auxiliary lift extended)	Overall Height (lowered)	Overall Height with OHG (extended)	Free Lift Height with OHG	Additional Lift	Load Capacity (w/o side shift)	Truck Weight (unloaded)
							24 in. LC	
		in	in	in	in	in	lbs	lbs
2-Stage Limited Free Lift	V355	170.7	93.5	227.2	0.0	29.9	2,205	6,841
3-Stage Full Free Lift	TF500	229.6	87.4	286.1	1.0	29.9	2,205	7,317
	TF530	240.7	93.5	297.2	7.1	29.9	2,205	7,410
	TF610	270.7	105.5	327.2	19.1	29.9	1,819	7,592
	TF685	300.7	117.5	357.2	31.1	29.9	1,433	7,800
	TF760	330.7	129.3	387.2	42.9	29.9	1,213	8,101
	TF930	396.9	158.5	453.4	72.0	29.9	772	8,665

* TF-Mast: A mast with 1 free lift cylinder in the center.
 * When TF Mast is applied, the overall width increases.

Load Capacity

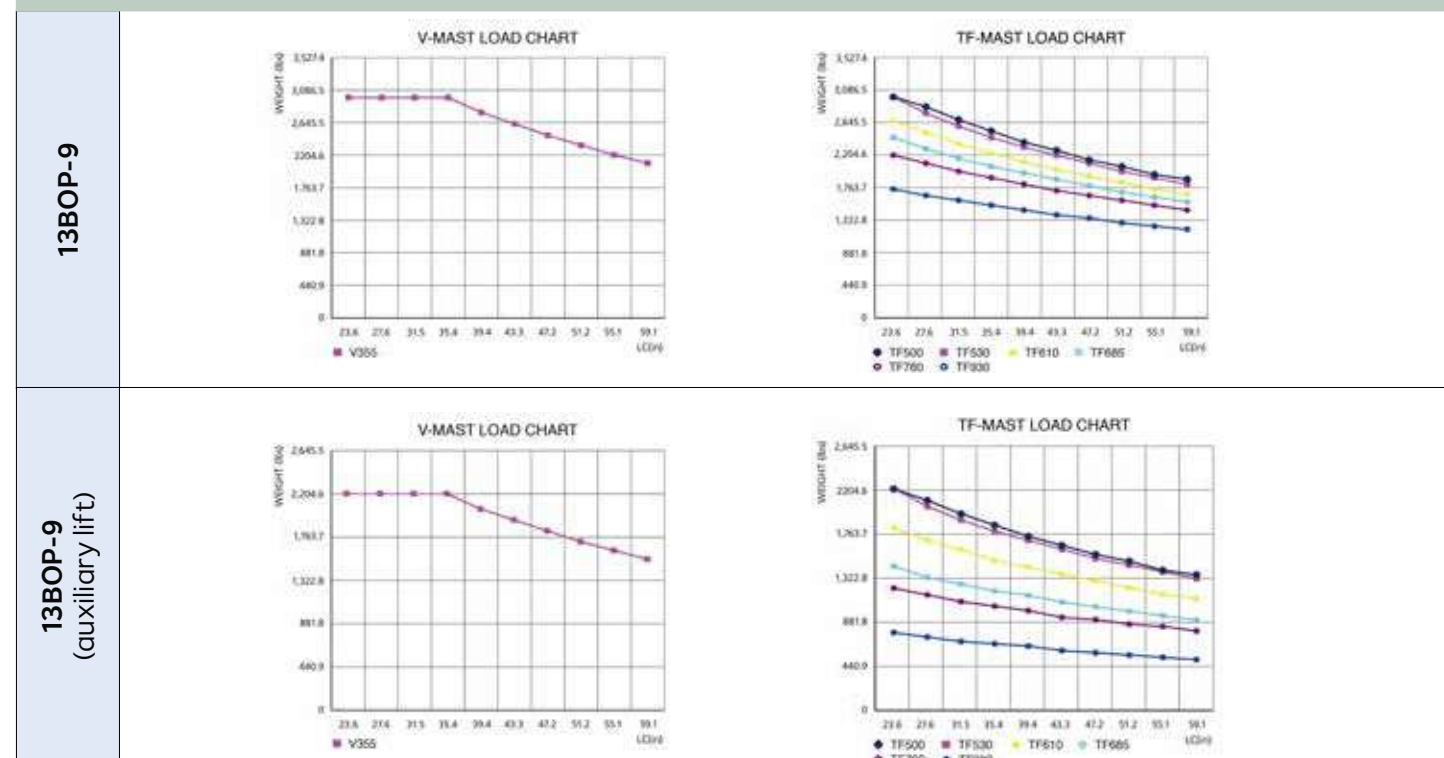

HI-MATE MANAGEMENT SYSTEM

Hi-Mate is one of the industry's most advanced remote management systems. With continuous data collection, Hi-Mate delivers more communication, control, and ability to track, monitor, maintain, and manage your forklift fleet. It is the proven way to efficiently coordinate both your equipment and human resources.

ONLY HYUNDAI OFFERS YOU SUCH A COMPREHENSIVE, FULLY INTEGRATED TELEMATICS SYSTEM.

Hi-Mate works by collecting key data from sensors mounted to your equipment that track operation of the forklift, relaying that information to your computer or mobile device in real time. By monitoring key components, such as the engine, electric system, and hydraulics, Hi-Mate can help you evaluate machine and operator performance, create preventive maintenance programs, and help you minimize downtime as you maximize productivity.



HiMATE



Equipment operation management

Real-time monitoring and follow-up management of individual pieces of equipment or equipment fleet deliver essential operational status and information, including:

- Key-on time, travel hours, work hours, and GPS location



Equipment status management

Vital diagnostic and maintenance data is relayed as alerts, while Hi-Mate Premium provides tracking of pre-shift checklists to help reduce downtime and ensure OSHA compliance:

- Alerts are sent for DTCs, system warning, and required maintenance



Safe traveling control

An impact monitor provides alerts, accountability, and follow-up management of safety incidents involving equipment during operation:

- The system logs the number and severity of impacts as well as the operator who was logged into the unit at the time of the incident



Human resource management

Hi-Mate Premium can control who operates equipment via a pin pad and RFID reader:

- Provided information can be used to evaluate productivity, efficiency, and workforce safety
- Tracking the weight load indicator captures operator productivity

Data Flow

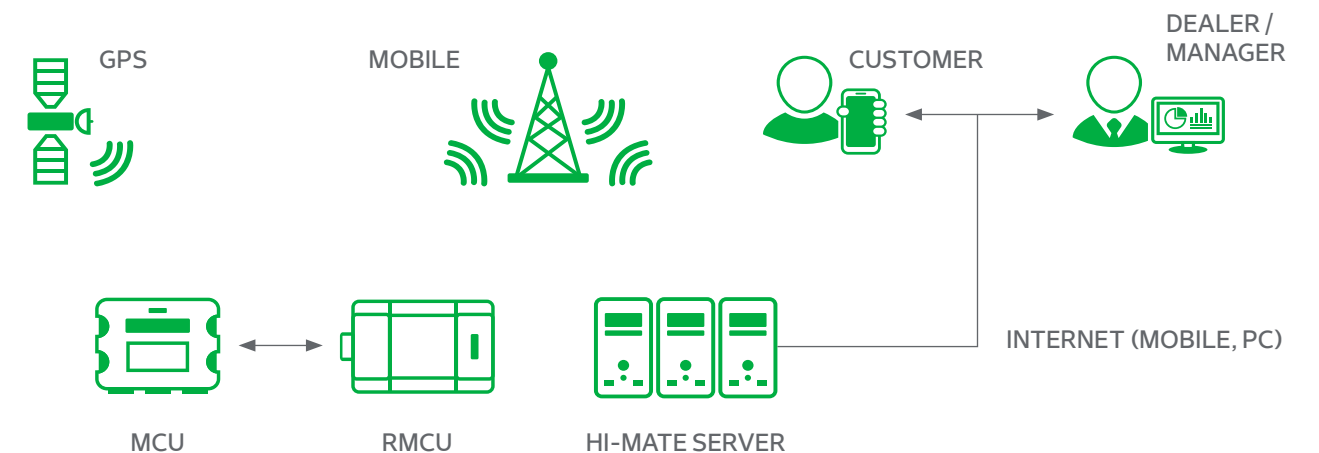

Options

Fork Length (in)

- 35.4 (std)
- 47.2
- 53.2
- 59.1
- 63.0
- 74.8

Guide Roller (Wide Frame) (in)

- 48.3
- 49.5 (57.3)
- 50.4 (58.3)
- 51.3 (59.2)

Battery Voltage

- 36v

Tire

- Vulkollan®

Beacon Lamp

- Blue
- Red

Wire Guidance

Height Indicator

**NO ONE
DELIVERS MORE**



6100 Atlantic Blvd.
Norcross, GA 30071
hyundaiforkliftamericas.com

678-823-7777