

45PPW Powered Pallet Walkie 4500 LBS

ADVANTAGES

- Ergonomic, Compact and Safe Long Tiller Design
- Reliable and Strong Chassis
- Powerful, Maintenance Free German AC Power Train
- Core Components from Top Quality Brands



German AC drive technology

The powerful German Schabmueller maintenance free AC Drive motor in combination with the German Kordel gearbox, Intorq brake and Wicke drive wheel give best performance, efficiency and reliability to reduce the running costs! Whatever desired, the AC Drive gives always the right response: gentle or fast acceleration.



Long tiller design for ergonomics and safety



The long tiller design keeps the operator at a safe distance from the truck while working safely and efficiently.

The design ensures lower operational forces than trucks with a short tiller. The tillers operating height is naturally positioned to ergonomic, operator friendly controlling positions.



Long lasting battery capacity

45PPW with 24v/210 Ah battery with short truck length and maneuverability for restricted operating areas.

Various options

- Load backrest
- Sideways battery exchange
- Different fork-versions on request

Entry rollers as standard.

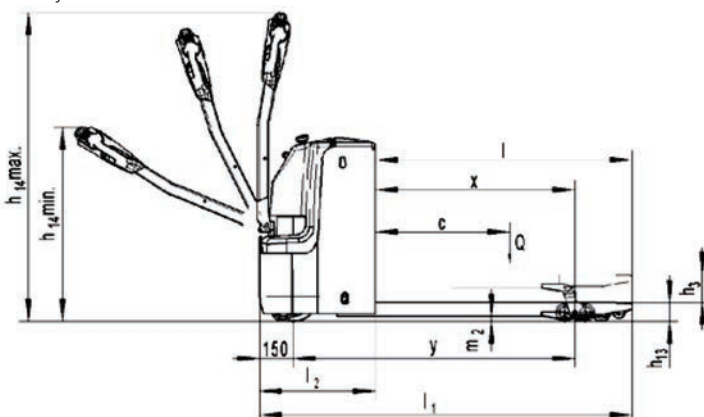

CAN-Bus technology

The CAN-Bus technology, due to less wiring is more reliable. For maintenance the CAN-Bus technology makes analysis and adjustments easier so that the downtime is lower than for trucks without CAN-Bus. Digital signals further makes parts longer lasting than analogue signals.

CAN-Bus

Maintenance friendly



The trucks components are tailored to make service and maintenance easy. All components are easy to reach by removing the main cover. The drive and castor wheels are easy to replace without craning the truck.

Robust and reliable design

The robust chassis with the strong 8 mm thick apron protects the truck and the components against mechanical impacts from the outside.

In combination with the strong metal battery cover, the truck is well- equipped to reduce service work and damages to a minimum.

Dirty floor environments have less influence to the vertical AC motor design as the components and the brake are out of the reach of direct impacts. IP 54 protected controller, safe against dust and splash water.

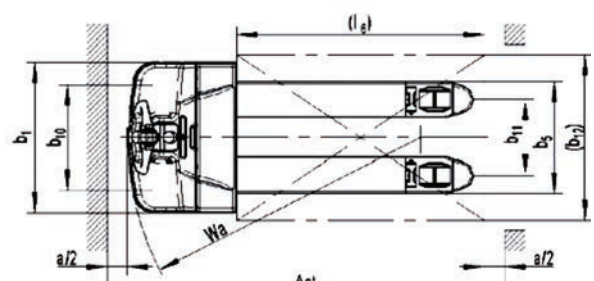

Distinguishing mark

1.1	Manufacturer		Hyundai
1.2	Manufacturer's Model Designation		45PPW
1.3	Power Type / Electric, Diesel, LP		Electric
1.4	Operator type		Pedestrian
1.5	Load Capacity	Q (lbs)	4,500
1.6	Load centre distance	C (in)	24
1.8	Load Distance, Center Of Drive Axle To Fork	X (in)	35.1
1.9	Wheel base distance	y (in)	53.3

Weight

2.1	Truck weight		lbs	1,177
2.2	Axle Loading, Loaded	Front / Rear	lbs	1,881 / 3,696
2.3	Axle Loading, Unloaded	Front / Rear	lbs	913 / 264

Tires, chassis

3.1	Tire type solid (V) pneumatic (P), polyurethane (PE)			Polyurethane (PU)
3.2	Front tire size		0 x width (in)	9.1 / 2.8
3.3	Rear tire size		0 x width (in)	3.3 / 3.3
3.4	Additional Wheels (caster)		0 x width (in)	3.9 / 1.6
3.5	Wheels, number front / rear (x = driven wheels)			1x +2 / 2
3.6	Track width (front)		b10 (in)	20.0
3.7	Track width (rear)		b11 (in)	14.4 / 2.0.2

Dimensions

4.4	Lift Height		h3(in)	4.7
4.9	Height of tiller in drive position min. / max.		h14(in)	32.2 / 52.2
4.15	Height , lowered		h13(in)	3.3
4.19	Overall length		l1 (in)	68.3
4.20	Length to face of forks		l2 (in)	23.4
4.21	Overall width		b1 (in)	28.7
4.22	Fork dimensions		s/e/1 (in)	2.4 / 6.8 / 45.3
4.25	Distance between fork arms		b5 (in)	21.3 / 27.0
4.32	Ground clearance center of wheelbase		m2 (in)	1.0
4.34	Aisle width for 40 x 48 crossways		Ast (in)	77.0
4.34	Aisle width for 32 x 48 lengthways		Ast (in)	78.9
4.35	Ground clearance center of wheelbase		m2 (in)	58.7

Performance

5.1	Travel speed, Loaded / unloaded		mph	3.5 / 3.7
5.2	Lift speed, loaded / unloaded		fpm	4.3 / 5.9
5.3	Lowering speed, loaded / unloaded		fpm	6.9 / 6.9
5.8	Max. gradeability, loaded / unloaded		%	8/15
5.10	Service brake			Electromagnetic

Motors

6.1	Drive motor rating S2 60 min		HP	1.7
6.2	Lift motor rating at S3 10%		HP	1.1
6.3	Battery acc. to DIN 43531 /35 / 36 A, B, C, no			no.2Pzs
6.4	Battery voltage, nominal capacity K5		V/Ah	24 / 210
6.5	Battery weight (minimum)		lbs	473
8.1	Type of drive control		lbs	AC-Speed control
8.4	Sound level at driver's ear acc. to EN 12053		dB(A)	69
8.6	Steering			Mechanical

45PPW

Long-tiller Powered Pallet Walkie

The 45PPW series is the first choice for loading and unloading as well as for universal transportation on short distances with the capacities of 4,500 lbs.

With its high-quality and state of the art top-brand components and technologies, the truck competes with leading well-known brands in the market.



AUTHORIZED DEALER

Hyundai Material Handling

6100 Atlantic Blvd.
Norcross, GA 30071
P: 678-823-7777
TF: 1-877-509-2254
F: 678-823-7778
hyundaiforkliftamericas.com

45PPW 02/21 v.6